

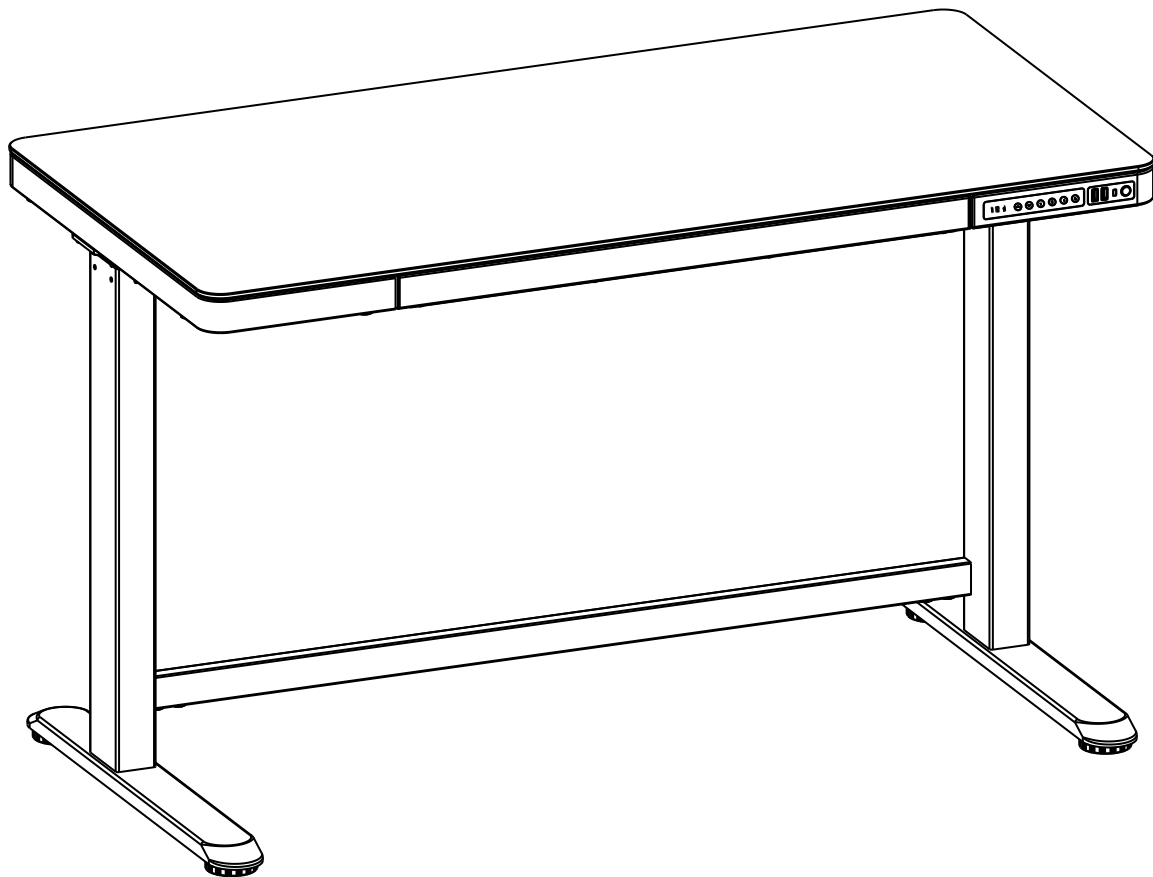

**Living**Essentials  
Corp.



**Jefferson Electric Height  
Adjustable Desk - Black  
SKU# SDMBK0347**

**Instruction Manual**



LivingEssentials  
Corp.

***For faster service:  
Please contact Living Essentials  
Regarding any defective product(s) / Part(s).***

***Our Customer Service Representative will assist you  
through the process of obtaining replacement part(s) .***

***Visit our website and fill out the Parts & Service Form,  
Give us a call, or email us for replacement parts at:***

**1-888-818-8789  
rma@livingess.com**

LIVING ESSENTIALS  
1040 Walnut Ave.  
Pomona, CA 91766  
Attention: Customer Service Department

#### **Limited Warranty**

LIVING ESSENTIALS' products are warranted to be free from defects in material and workmanship for a period of ONE YEAR: One-year warranty from date of original purchase by consumer. If you believe your product is defective, please call, write, or e-mail our customer service department.

Should your product be defective, LIVING ESSENTIALS will help in issuing replacement parts. Whether you call or write, please have your model number and reference number located on the original packaging ready for our customer service team. You will be asked to tell us what product you have, along with the date of purchase and the way you believe the product is defective. For any parts request, it must include images of the defective part/s. Please do not ship your product back to us unless we specifically request you to do so. If it is necessary for your product to be returned, all returns or exchanges must be made through the original store of purchase. Proof of purchase must accompany the returned product. LIVING ESSENTIALS is not responsible for any store policies for returns or exchanges.

**Note: This Warranty does NOT apply to any wear and tear. All replacement parts will be shipped standard ground service. NO EXPEDITED Service available (for example; next day air, 2 day air service, 3 day air), there will NOT be any exceptions.**

**LIVING ESSENTIALS is not responsible for any consequential damages, which may arise out of the purchase, or use of any of our product/s. LIVING ESSENTIALS is not responsible for any personal injury, or property/equipment damage from the use of such product/s. LIVING ESSENTIALS' liability for any breach of warranty shall be limited to replacement of the defective parts as described above.**

Important: Some states do not allow the exclusions or limitations so the above limitations or exclusions may not apply to you.

Copyright by: LIVING ESSENTIALS and its affiliates



**Instructions / Instrucciones / Moded' emploi**

**Jefferson Electric Height Adjustable Desk - Black - SKU# SDMBK0347**

- Do not tighten bolts completely until the product is fully assembled.
- Por favor de apretar los tornillos hasta que haya ensamblado el producto completamente.

1. Tabletop X1

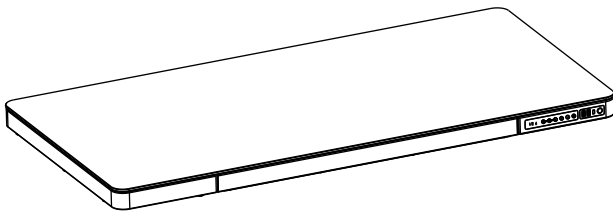

2. Lifting columns X1

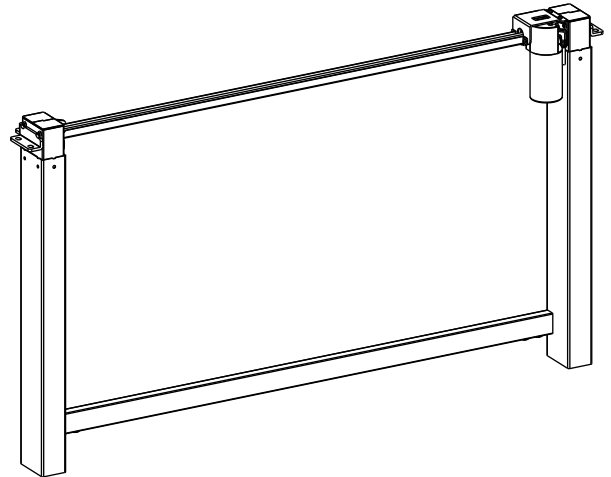

3. Feet X2

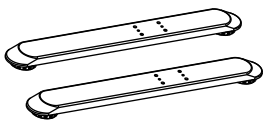

4. Power plug X1

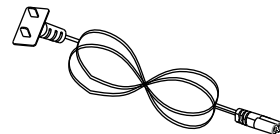

Attention: The drawings are for guidance only and they may differ slightly from the product and fittings received. Please contact our customer service department should you have any queries.

**Technical data**

Max. Weight Capacity	110lbs/50KG
Height Range	720- 1210mm
Drawer Stroke	230mm
Charging Ports/ Child Lock	

**A x8**



M6

**B x8**



M8

**C x1**

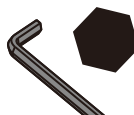

5x5

**D x2**

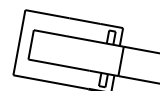

Cable clamp

# STEP 1

Install the tabletop and the lifting columns

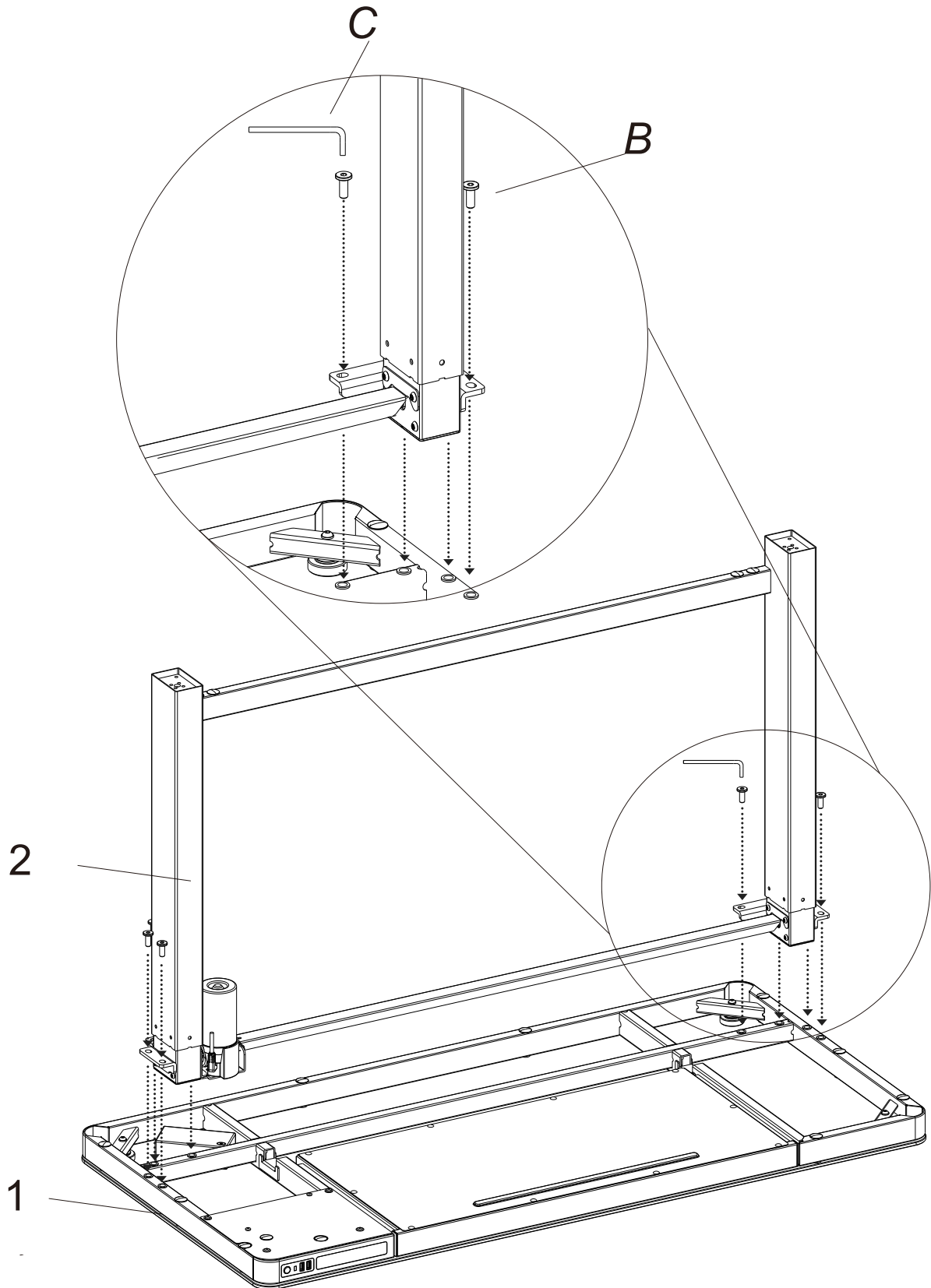

B x8



C x1



Connect the tabletop (1) and the lifting columns (2) with the screw (Bx8) M8 and tighten it them with the hex wrench (C).  
Caution: Please do not touch the glass surface directly to the ground during installation, so as not to be scratched by sharp objects on the table; Please be careful during installation to avoid falling and breaking the glass.

**STEP 2**

Install the feet

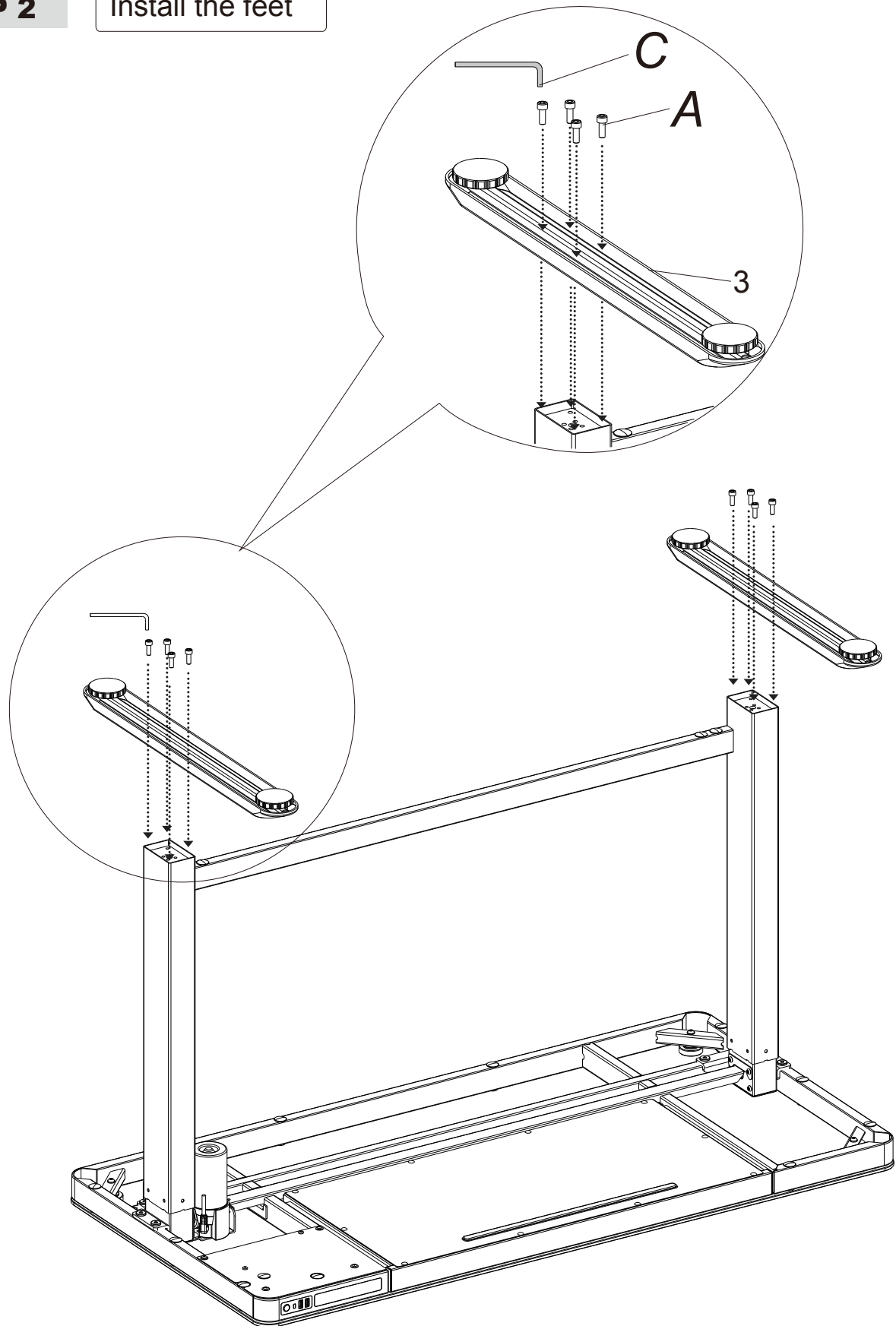

A x8



C x1



Install the feet (3) to the lifting columns with the screw M6 (A\*8) and tighten them with the hex wrench (C).  
Caution: Please be careful during installation to avoid falling and breaking the glass; Pay attention to the directions.

### STEP 3

Install the motor and power lines

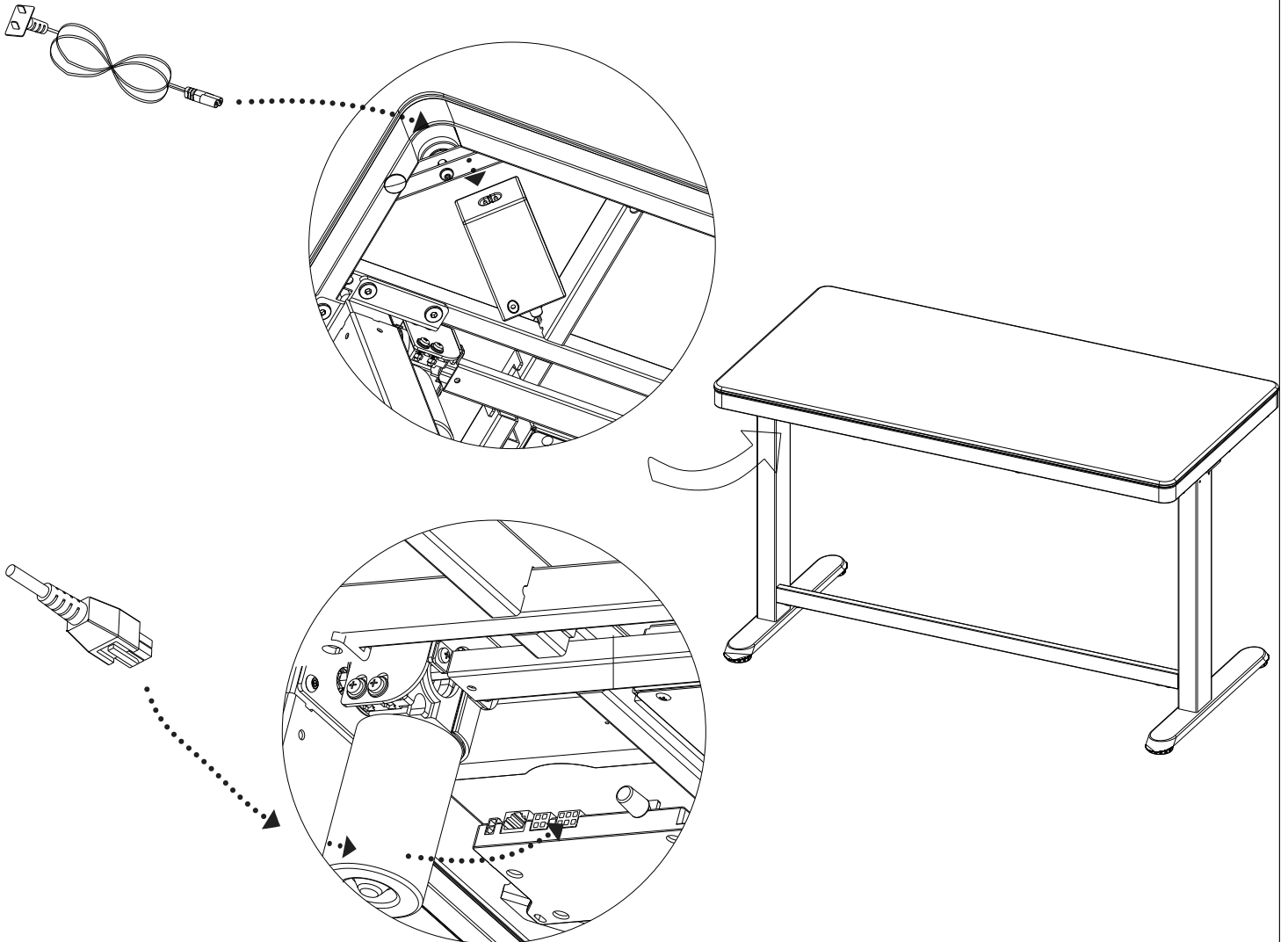

#### 4. Power plug X1

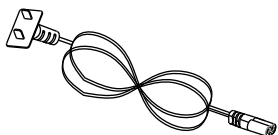

Connect the motor plug to the control box, then connect one side of the adapter plug to the adapter, another side to the power line.  
Caution: the motor and power lines can be fixed with cable clamps according to actual use.

## Operation Instruction

### Key button



1. Long press the up/down buttons to adjust the height of the desk; The screen will show "bot" when the desktop runs to its lowest point; and it will show "top" when the desktop runs to its highest point.
2. key button: 1,2,3,4 are the four height memory buttons, long press the button about 3s can record the current height;
3. Press the 3 and 4 buttons at the same time, the RST reset indication will appear. Continue to press the "▼" down button until the lifting table lowers to the lowest position and rebounds to rise to a stop. The display shows the lowest height "bot", release "▼" down button, the reset is over and the table can be used normally.
4. The desk has two USB, one type-C ports, they can supply power to other electronics. Every channel can maximum output DC 5V/2.4A power when the desktop is stationary and will stop output when the desktop is running. It will resume output after 5s of inactivity.
5. Short press the "LOCK" button to achieve the child lock function, so as to avoid accidentally touch and guarantee the safety of children; The child lock button is switchable, screen will show "Loc" when the desk is locked.
6. Long press the up and down button to switch the sensitivity level. When the screen shows "A-0", it means the anti-collision function is off, "A-1" means the anti-collision sensitivity is in level 1, "A-2" means the anti-collision sensitivity is in level 2, "A-3" means the anti-collision sensitivity is in level 3, level 3 means the highest sensitivity.

### Troubleshooting:

- a. Reset: When the LED shows "RST", press "▼" button until the desk reaches its lowest height and rebounds to stop, it means the reset has been finished.
- b. When it doesn't work and the LED shows "E01" or "E02", please retry 18 mins later.
- c. If the "▼" button doesn't work, please check the cable connection and then cut off the power for at least 10 seconds. Reconnect to the power and press "▼" button to start the reset process when it shows the "RST".
- d. If all these above process are inefficient, plz contact our customer service.

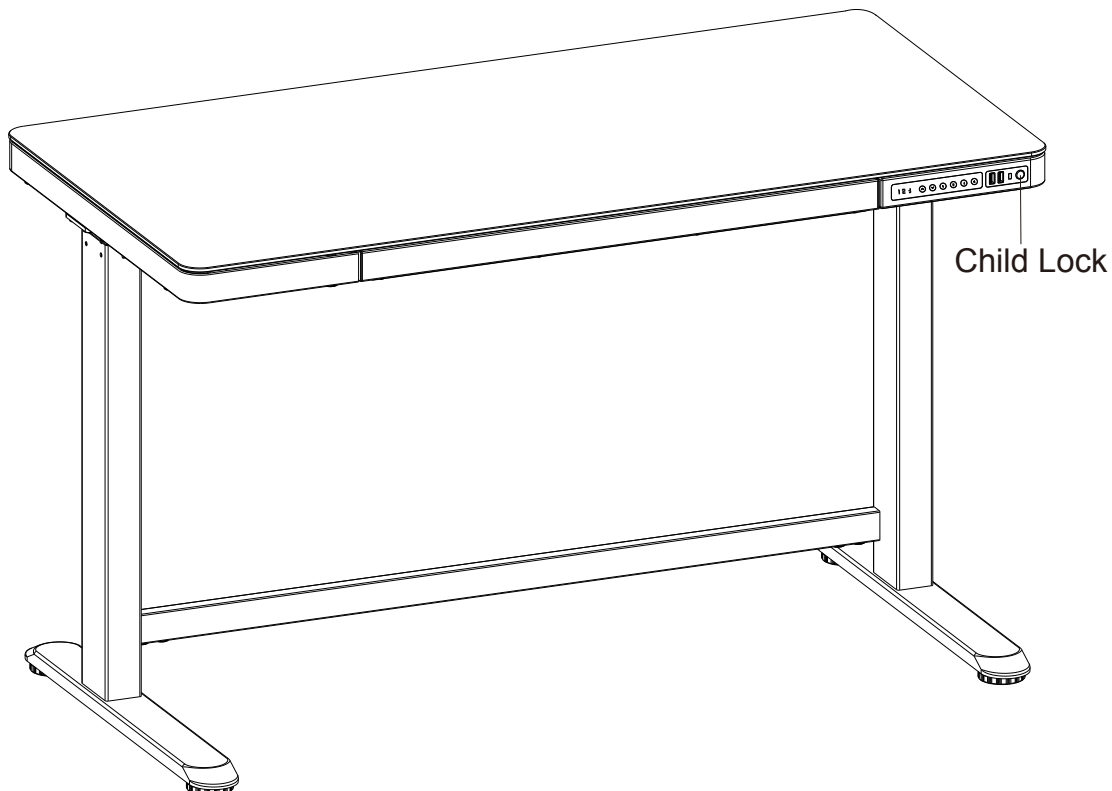

## Common fault treatment

The following tips will help you detect and eliminate common faults and errors.  
 If specific errors are not listed below, please contact your supplier.  
 Only the manufacturer and professionals are capable of investigating and correcting the defects.

Issues	Method
No response when long pressing down arrow after connected with a power supply	1. Check if all the cables are connected well
	2. Contact your supplier or dealer
No response when pressing up arrow/ down arrow after connecting to power supply	1. Check if all the cables are connected well
	2. Contact your supplier or dealer
Rising at low speed	1. Check if overloaded, max loading: 50kg;
	2. Contact your supplier or dealer
Motor does not move as instructed	1. Contact your supplier or dealer
Goes down but not up	1. Reposition
	2. Contact your supplier or dealer
Downward sliding	1. Check if overloaded, max loading: 50kg;
	2. Contact your supplier or dealer
Frequently repositioning	1. Check if overloaded, max loading: 50kg;
	2. Contact your supplier or dealer
Overwork (Duty cycle: Max 2min on/18min OFF)	1. Restart after suspend for 18mins while connecting with power;
	2. Contact your supplier or dealer;



## Attention

1. Power supply: AC100V- 240V, 50/60Hz
2. Service Environment: 0-40°C
3. Unplug the power plug before cleaning, wipe the dust on surface with slightly damp dishcloth when cleaning, be careful not to get water into the internal components, do not lose the connector.
4. The electric box contains electronic components, metals, plastics, wires etc., so dispose of it in accordance with each country's environmental legislation, not the general household waste.
5. Check carefully to ensure correct and complete assembly before using.
6. Be familiar with all functions and program settings of the product before first use.
7. Children are forbidden to play on the desk as the behavior is unpredictable. Manufacturer is not responsible for loss, injury, or damage due to improper actions.
8. Slight noise caused by the V-ribbed belt or brake system due to structure will not have any effect on the use of the equipment.
9. Corrosive or abrasive materials are forbidden to clean the equipment. Ensure that the cleaner used will not pollute the environment.
10. This appliance can be used by children aged from 8 years and above and persons with reduced physical, sensory or mental capabilities or lack of experience and knowledge if they have been given supervision or instructions concerning use of the appliance in a safe way and understand the hazards involved. Children shall not play with the appliance.
11. Cleaning and user maintenance shall not be made by children without supervision.
12. If the supply cord is damaged, it must be replaced by the manufacturer, its service agent or a similarly qualified person in order to avoid a hazard.
13. Please make sure there is no hazard sources in your operating environment. e.g., do not litter the tools around. Always be careful to treat the packaging materials in order to avoid any possible danger, e.g. plastic bag may lead to choking hazard to children.
14. Keep the original package of the equipment if necessary in case of future need for transportation.

## Waste disposal

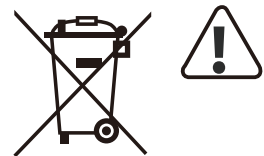

This marking indicates that this product should not be disposed of with other household wastes. To prevent possible harm to the environment or human health from uncontrolled waste disposal, recycle it responsibly to promote the sustainable reuse of material resources. To return your used device, please use the return and collection systems or contact the retailer where the product was purchased. They can take this product for environmental safe recycling.